

Shower Channel - Glass Grate

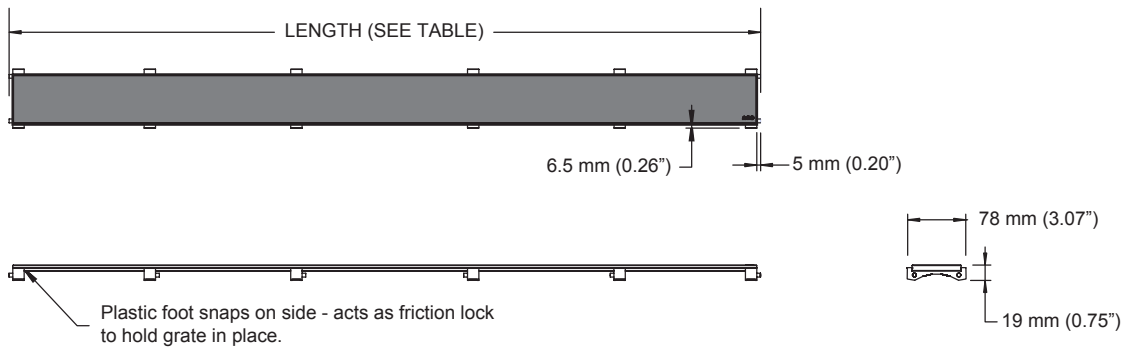

Product Table

Length mm (in)	700 (27.55)	800 (31.50)	900 (35.43)	1000 (39.37)	1200 (47.24)	Replacement grate lifting key	Foot Color
Width mm (in)	78 (3.07)	78 (3.07)	78 (3.07)	78 (3.07)	78 (3.07)	n/a	
Part No. Black	9010.56.67	9010.56.68	9010.56.69	9010.56.70	9010.56.71	37339	
Part No. White	9010.56.72	9010.56.73	9010.56.74	9010.56.75	9010.56.76	37339	
Part No. Gray	9010.56.77	9010.56.78	9010.56.79	9010.56.80	9010.56.81	37339	
Weight kg (lbs)	0.77 (1.7)	0.86 (1.9)	0.99 (2.2)	1.08 (2.4)	1.31 (2.9)	0.04 (0.1)	
Intake area sq. cm (sq. in)	99.29 (15.39)	114.25 (17.71)	129.22 (20.03)	144.19 (22.35)	172.12 (26.68)	n/a	

Specification Clause

The QuARTz ACO ShowerDrain channel shall be stainless steel grade 304 3mm bar with anti-slip nodules, and the grate shall be tempered glass, manufactured by ACO, Inc. and supplied by ACO Systems, Ltd.

The surface finish shall be Glass.

Grate shall be 78 mm (3.07") wide, with length as specified on Architects plans / Architects specification.

Shower channel shall be Plain Edge OR Flanged Edge. (See separate Spec Info Sheet for details)

ACO recommends checking local plumbing codes prior to installation.

The system shall be installed in accordance with the manufacturer's instructions and recommendations.

ACO Systems, Ltd.

East Office
1-2880 Brighton Rd.
Oakville, ON L6H 5S3
Tel: (905) 829-0665
Fax: (905) 829-2908

West Office
118-1750 Coast Meridian Rd.
Port Coquitlam, BC V3C 6R8
Tel: (604) 554-0688
Fax: (604) 554-0693



Electronic Contact:
Eml: info@acocan.ca
Web: www.quartzbyaco.ca

